



## PSEN ma1.3n-20

**PILZ**  
THE SPIRIT OF SAFETY

► PSEN sensor technology

This document is the original document.

All rights to this documentation are reserved by Pilz GmbH & Co. KG. Copies may be made for the user's internal purposes. Suggestions and comments for improving this documentation will be gratefully received.

Source code from third-party manufacturers or open source software has been used for some components. The relevant licence information is available on the Internet on the Pilz homepage.

Pilz®, PIT®, PMI®, PNOZ®, Primo®, PSEN®, PSS®, PVIS®, SafetyBUS p®, SafetyEYE®, SafetyNET p®, the spirit of safety® are registered and protected trademarks of Pilz GmbH & Co. KG in some countries.



SD means Secure Digital

<b>Introduction</b> .....	<b>4</b>
Validity of documentation .....	4
Using the documentation .....	4
Definition of symbols .....	4
<b>Safety</b> .....	<b>5</b>
Intended use .....	5
Safety regulations .....	5
Safety assessment .....	5
Use of qualified personnel .....	6
Warranty and liability .....	6
Disposal .....	6
For your safety .....	6
<b>Unit features</b> .....	<b>7</b>
<b>Function description</b> .....	<b>7</b>
Block diagram .....	8
Operating distances .....	8
Lateral and vertical offset .....	9
<b>Wiring</b> .....	<b>11</b>
Pin assignment .....	11
<b>Requirements and connection to evaluation devices</b> .....	<b>12</b>
<b>Installation</b> .....	<b>15</b>
<b>Adjustment</b> .....	<b>18</b>
<b>Periodic test</b> .....	<b>18</b>
<b>Dimensions in mm</b> .....	<b>18</b>
<b>Technical details</b> .....	<b>19</b>
Safety characteristic data .....	21
<b>Order reference</b> .....	<b>22</b>
System .....	22
Accessories .....	22
<b>EC declaration of conformity</b> .....	<b>23</b>

## Introduction

### Validity of documentation

This documentation is valid for the product PSEN ma1.3n-20/with cube. It is valid until new documentation is published.

This operating manual explains the function and operation, describes the installation and provides guidelines on how to connect the product.

### Using the documentation

This document is intended for instruction. Only install and commission the product if you have read and understood this document. The document should be retained for future reference.

### Definition of symbols

Information that is particularly important is identified as follows:



#### **DANGER!**

This warning must be heeded! It warns of a hazardous situation that poses an immediate threat of serious injury and death and indicates preventive measures that can be taken.



#### **WARNING!**

This warning must be heeded! It warns of a hazardous situation that could lead to serious injury and death and indicates preventive measures that can be taken.



#### **CAUTION!**

This refers to a hazard that can lead to a less serious or minor injury plus material damage, and also provides information on preventive measures that can be taken.



#### **NOTICE**

This describes a situation in which the product or devices could be damaged and also provides information on preventive measures that can be taken. It also highlights areas within the text that are of particular importance.

**INFORMATION**

This gives advice on applications and provides information on special features.

**Safety****Intended use**

The safety function of the safety switch is:

- ▶ Safe detection of the magnetic actuator within the response range

The safety switch meets the requirements in accordance with:

- ▶ EN 60947-5-3: PDDB only in connection
  - with the operator PSEN ma1.3-08 or operator PSEN ma1.3-12 and
  - the suitable evaluation devices (see [Requirements and connection to evaluation devices](#)  12]).

The following is deemed improper use in particular

- ▶ Any component, technical or electrical modification to the product,
- ▶ Use of the product outside the areas described in this manual,
- ▶ Use of the product outside the technical details (see [Technical details](#)  19]).

**NOTICE****EMC-compliant electrical installation**

The product is designed for use in an industrial environment. The product may cause interference if installed in other environments. If installed in other environments, measures should be taken to comply with the applicable standards and directives for the respective installation site with regard to interference.

**Safety regulations****Safety assessment**

Before using a device it is necessary to perform a safety assessment in accordance with the Machinery Directive.

Functional safety is guaranteed for the product as a single component. However, this does not guarantee the functional safety of the overall plant/machine. In order to achieve the required safety level for the overall plant/machine, define the safety requirements for the plant/machine and then define how these must be implemented from a technical and organisational standpoint.

### Use of qualified personnel

The products may only be assembled, installed, programmed, commissioned, operated, maintained and decommissioned by competent persons.

A competent person is a qualified and knowledgeable person who, because of their training, experience and current professional activity, has the specialist knowledge required. To be able to inspect, assess and operate devices, systems and machines, the person has to be informed of the state of the art and the applicable national, European and international laws, directives and standards.

It is the company's responsibility only to employ personnel who

- ▶ Are familiar with the basic regulations concerning health and safety / accident prevention,
- ▶ Have read and understood the information provided in the section entitled Safety
- ▶ Have a good knowledge of the generic and specialist standards applicable to the specific application.

### Warranty and liability

All claims to warranty and liability will be rendered invalid if

- ▶ The product was used contrary to the purpose for which it is intended,
- ▶ Damage can be attributed to not having followed the guidelines in the manual,
- ▶ Operating personnel are not suitably qualified,
- ▶ Any type of modification has been made (e.g. exchanging components on the PCB boards, soldering work etc.).

### Disposal

- ▶ In safety-related applications, please comply with the mission time  $T_M$  in the safety-related characteristic data.
- ▶ When decommissioning, please comply with local regulations regarding the disposal of electronic devices (e.g. Electrical and Electronic Equipment Act).

### For your safety



#### WARNING!

#### Loss of safety function due to manipulation of the interlocking device

Manipulation of the interlocking device may lead to serious injury and death.

- You should prevent any possibility of the interlocking device being manipulated through the use of a spare actuator.
- Keep the substitute actuator in a safe place and protect it from unauthorised access.
- If spare actuators are used, these must be installed as described in [Installation](#) [ 15].
- If the original actuators are replaced with substitute actuators, the original actuators must be destroyed before disposal.

- ▶ Do not remove the connector's protective cap until you are just about to connect the unit. This will prevent potential contamination.



### Unit features

- ▶ The actuator PSEN ma1.3-08 or PSEN ma1.3-12 belongs to the safety switch.
- ▶ Coded actuator
- ▶ Safety switch with 5-pin M12 male connector
- ▶ 2 safety contacts (reed contacts - N/O)
- ▶ 1 auxiliary contact (N/O)
- ▶ Different operating distances depending on the actuator see [Technical details](#)  19]
- ▶ Design:
  - Safety switch with round design
  - Actuator with round design: PSEN ma1.3-08
  - Actuator with square design: PSEN ma1.3-12 (various directions of actuation possible)
- ▶ Operation Magnetic
- ▶ Switching voltage 24 VDC
- ▶ LED to display switch status

### Function description

If the actuator is within the response range (safety gate closed), the safety contacts and the auxiliary contact on the safety switch will be closed and the LED will light.

Operate the PSEN ma1.3n-20/with cube in conjunction with the following components:

- ▶ Actuator PSEN ma1.3-08 or actuator PSEN ma1.3-12 (see [Order reference](#)  22]) and
- ▶ a connected evaluation device (see [Requirements and connection to evaluation devices](#)  12]).

**Block diagram**

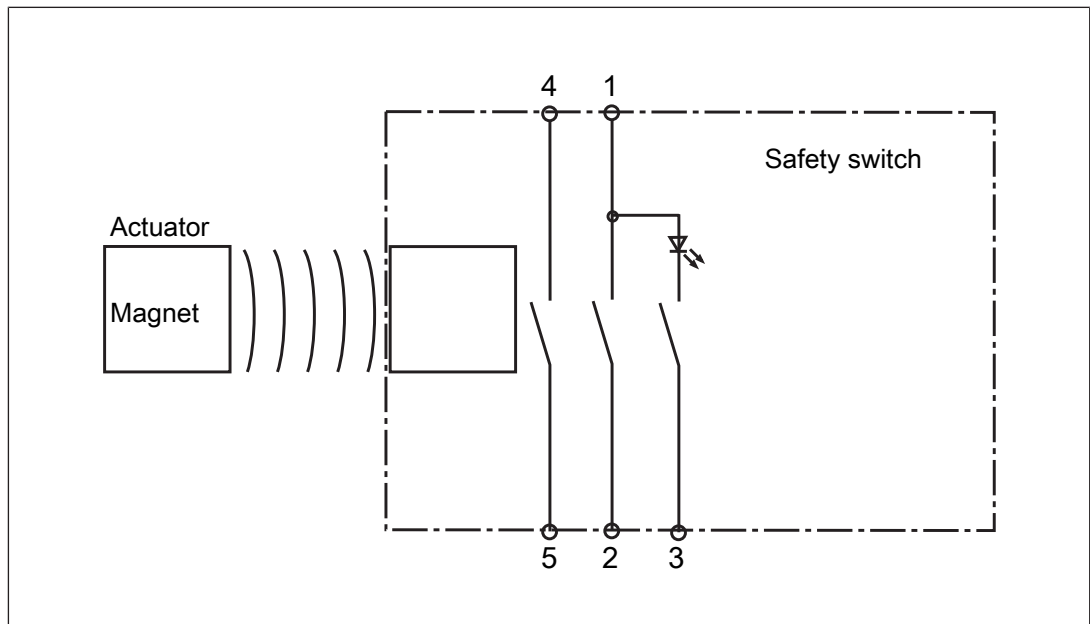

**Operating distances**

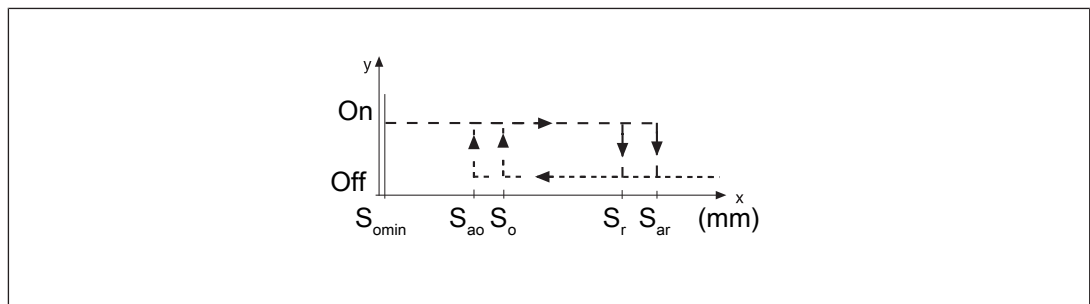

**Legend**

- $S_{ao}$  Assured operating distance
- $S_{omin}$  Min. operating distance
- $S_{ar}$  Assured release distance

The offset-independent values for the switching distances are included in the [Technical details \[19\]](#).

**Lateral and vertical offset**

**Actuator PSEN ma1.3-08**

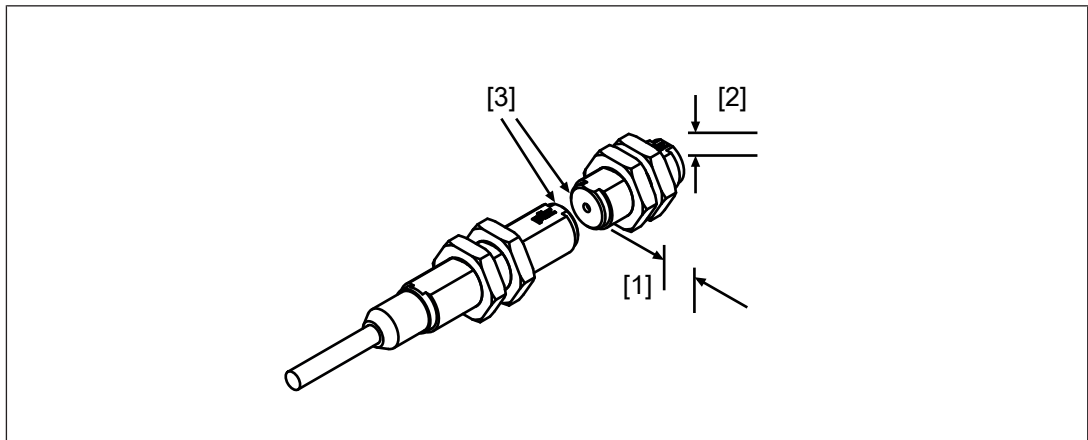

**Legend**

- [1] Lateral offset
- [2] Vertical offset
- [3] Sensing faces

**Assured operating distance  $S_{ao}$  in mm**

Lateral offset	Vertical offset		
	0	2	4
0	8.0	7.0	5.5
2	7.0	6.0	4.0
4	6.0	5.0	3.0

The stated values are valid at a temperature of 20 °C.

**Actuator PSEN ma1.3-12**

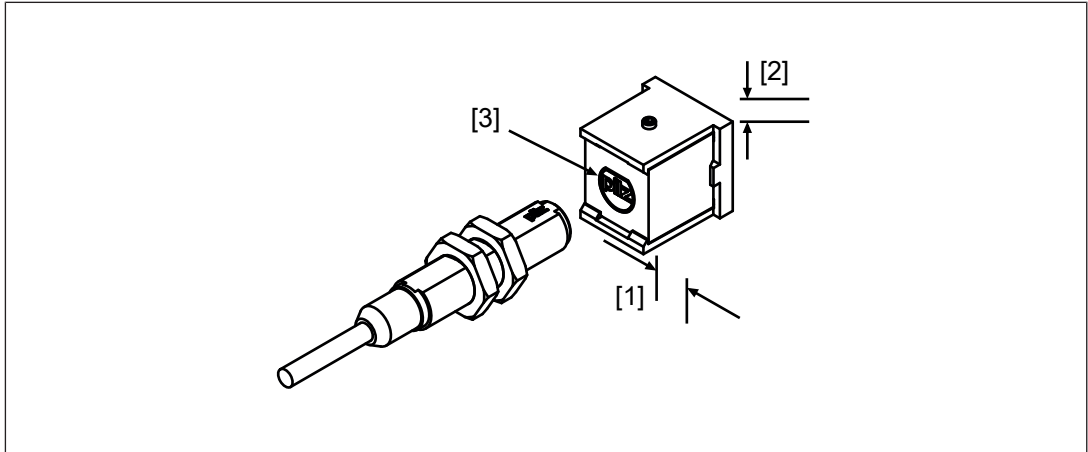

**Legend**

- [1] Lateral offset
- [2] Vertical offset
- [3] Sensing face

**Assured operating distance  $S_{ao}$  in mm**

Lateral offset	Vertical offset		
	0	1	2
0	12.0	10.0	8.0
2	12.0	10.0	8.0
4	11.0	9.5	7.5

The stated values are valid at a temperature of 20 °C.

**Negative vertical offset, not permitted**

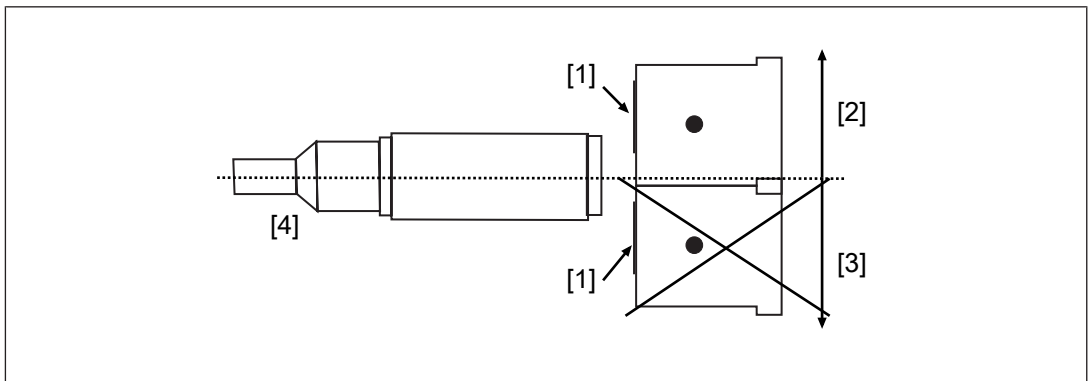

Fig.: Safety switch and square actuator - side view

**Legend**

- [1] Sensing face PSEN ma1.3-12
- [2] Positive vertical offset, permitted
- [3] Negative vertical offset, not permitted

[4] Safety switch

**Wiring**

- ▶ Information given in the [Technical details \[19\]](#) must be followed.
- ▶ Calculation of the max. cable length  $l_{max}$ :

$$l_{max} = \frac{R_{lmax} - R_i}{R_l / km}$$

$R_{lmax}$  = Max. overall cable resistance (see evaluation device's technical details)

$R_i$  = Internal resistance sensor (see [Technical details \[19\]](#))

$R_l / km$  = Cable resistance/km of the cable (see technical details cable)

- ▶ Ensure the wiring and EMC requirements of EN 60204-1 are met.
- ▶ In the following cases, check the function that detects shorts across contacts prior to commissioning:
  - On evaluation devices with DC supply voltage: Overall cable resistance  $\geq 15$  Ohms per channel
  - On evaluation devices with AC supply voltage: Overall cable resistance  $\geq 25$  Ohms per channel
  - For details of how to perform the test for shorts across the contacts, please refer to the operating manual for the relevant evaluation device.

**Pin assignment**



**NOTICE**

The colour marking for the connection lead only applies for the cable that Pilz supplies as an accessory

The safety switch is shown in an unoperated condition.

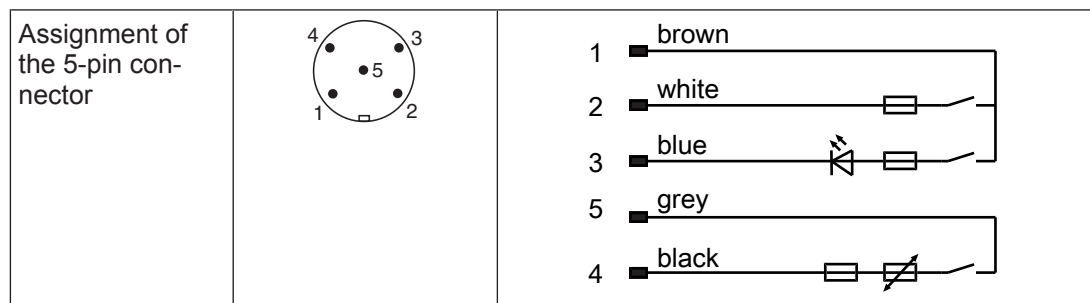

**NOTICE**

The auxiliary contact

- may only be operated with a supply voltage of up to 24 VDC
- can be connected in series
- may **not** be used for safety circuits

## Requirements and connection to evaluation devices

For use of PSEN ma1.3n-20/with cube in accordance with DIN EN 60947-5-3 an evaluation device must be connected.

Connect the PSEN ma1.3n-20/with cube

- ▶ **either** with a certified Pilz evaluation device
- ▶ **or** with an evaluation device with defined properties

**Certified Pilz evaluation devices are, for example:**

- ▶ PNOZelog for safety gate monitoring
  - PNOZ e1p, PNOZ e1.1p, PNOZ e1vp
  - PNOZ e5.11p
  - PNOZ e6vp, PNOZ e6.1p
- ▶ PNOZpower for safety gate monitoring
  - PNOZ p1p, PNOZ p1vp
- ▶ PNOZsigma for safety gate monitoring
  - PNOZ s3
  - PNOZ s4
  - PNOZ s5
- ▶ PNOZ X for safety gate monitoring
  - PNOZ X2, PNOZ X2.5P, PNOZ X2.7P, PNOZ X2.8P, PNOZ X2.9P, PNOZ X2C
  - PNOZ X3, PNOZ X3.1, PNOZ X3P, PNOZ X3.10P
  - PNOZ X4
  - PNOZ X5, PNOZ X5J
  - PNOZ Ex
- ▶ PNOZmulti for safety gate monitoring
  - Configure the switch in the PNOZmulti Configurator with switch type 3.
- ▶ PSS for safety gate monitoring with standard function block SB064, SB066 or FS\_Safety Gate
- ▶ PSSuniversal PLC for safety gate monitoring with function block FS\_SafetyGate

The correct connection to the respective evaluation device is described in the operating manual for the evaluation device. Make sure that the connection is made in accordance with the specifications in the operating manual for the selected evaluation device.

**Defined properties of evaluation devices:**

- ▶ 2-channel with feasibility monitoring
- ▶ Open circuit monitoring of the safety switch is performed
- ▶ Inputs and outputs on the evaluation device must fulfil the requirements of IEC 61131, Type 3
- ▶ Technical data of the evaluation device must fulfil the requirements in the [Technical details \[19\]](#) of PSEN ma1.3n-20/with cube
  - Always comply with the max. switching current safety contacts of PSEN ma1.3n-20/with cube.
- ▶ Outputs at the evaluation device must only be switched on again when both reed contacts at the safety switch have been opened and closed (partial operation lock)



**INFORMATION**

**Risk time in accordance with DIN EN 60947-5-3**

The risk time is made up of the reaction time of the sensor (see [Technical details \[19\]](#)) and the processing and delay times of the evaluation device (s. operating manual for the relevant evaluation device).

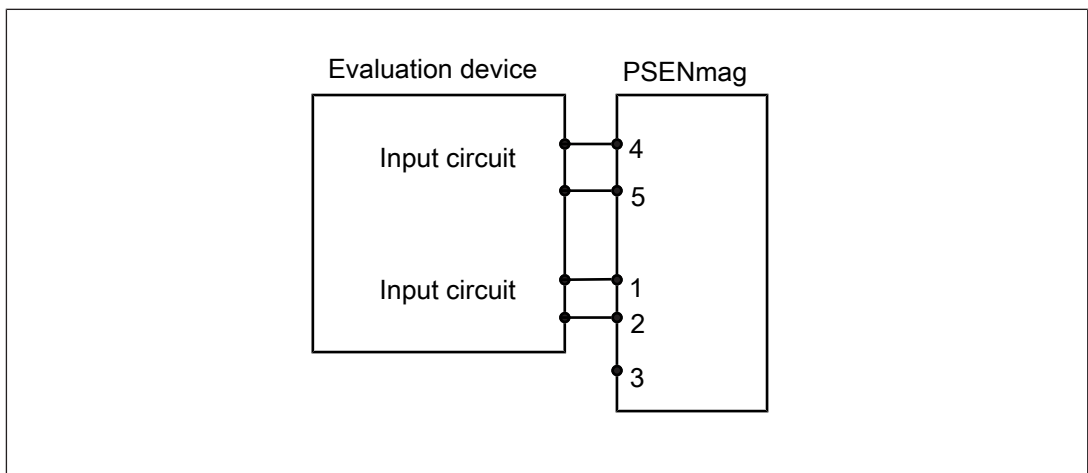
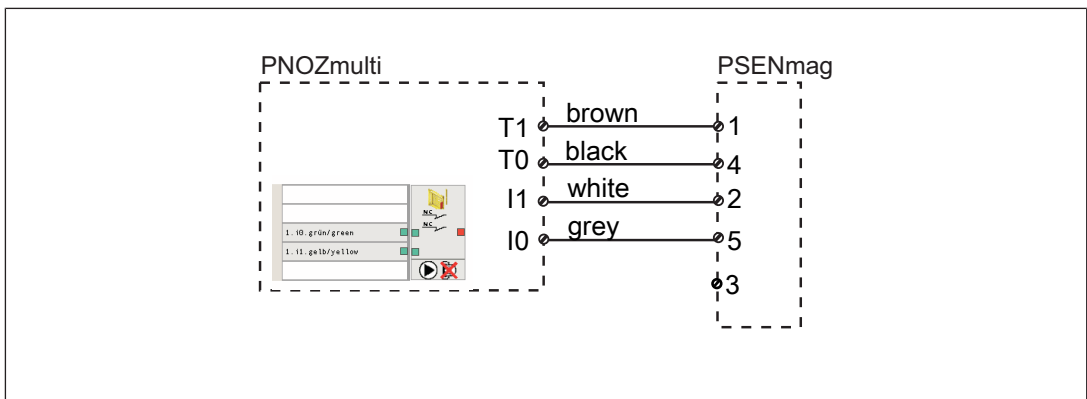
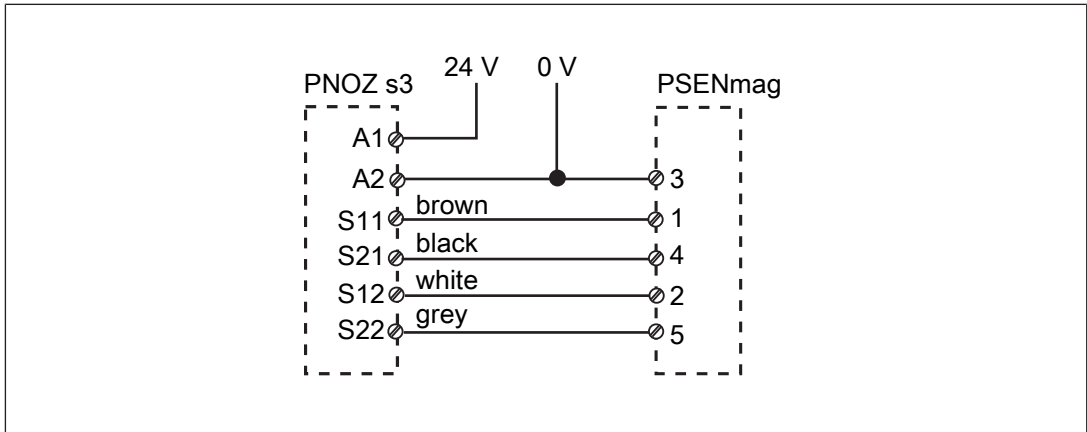

Fig.: Dual-channel connection PSEN ma1.3n-20/with cube to the input circuits of an evaluation device

**Examples for connection to Pilz evaluation devices:**



**Legend**

- I0 Input OSSD
- I1 Input OSSD
- T0 Test pulse output
- T1 Test pulse output

**Auxiliary contact with LED**

The auxiliary contact and the LED indicate the status of the safety contacts.

Actuator in the response range	Safety contacts and auxiliary contact	LED
Yes	Closed	☀ lights
No	Open	• Off

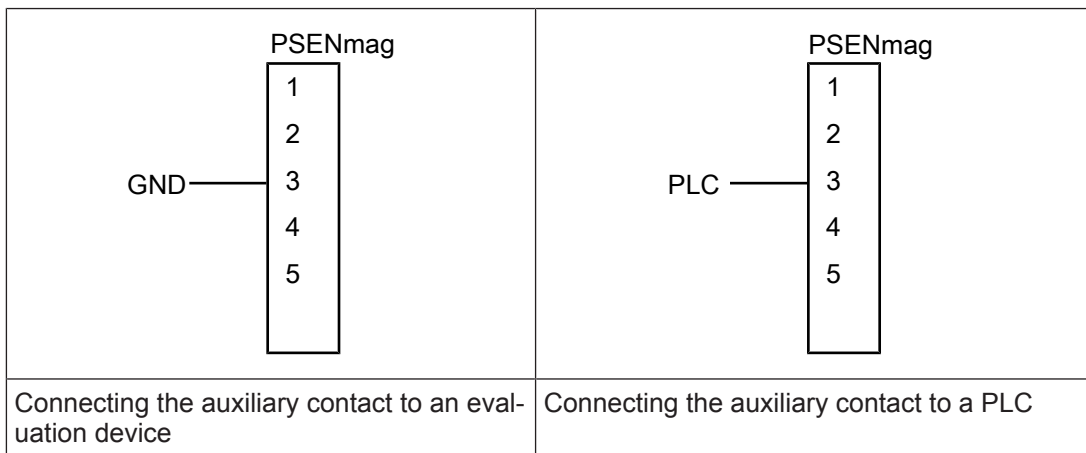

### Installation

- ▶ The unit can be installed in any position. Safety switches and actuators must be installed so that the bevelled surface on the safety switch and the bevelled surface of the actuator face each other precisely.



#### CAUTION!

##### Potential loss of safety function due to changed device properties

The unit's properties may be affected if installed in an environment containing electrically or magnetically conductive material.

- Please check the operating distances and the assured release distance.



#### CAUTION!

##### Possible loss of the safety function by changing the release distance $S_{ar}$ with non-flush installation

Installing the safety switch non-flush within electrically or magnetically conductive material, the value for the assured release distance  $S_{ar}$  can change.



- Check the assured release distance  $S_{ar}$ .

- ▶ Safety switches and actuators must be positioned so that they are secured against a change of position.
- ▶ Attach the safety switches and actuators only with the supplied nuts.
- ▶ Avoid the risk of damages from foreseeable external influences by attaching the safety switch and actuator. If necessary, safety switch and actuator have to be protected.





#### INFORMATION

Protect the actuator from unauthorised removal (e.g. via a screw lock or concealed installation) and from contamination.

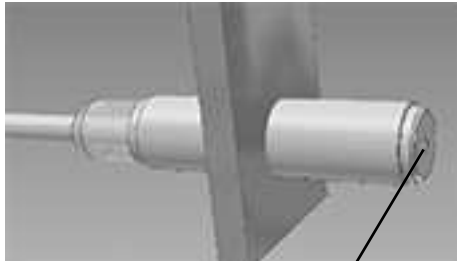
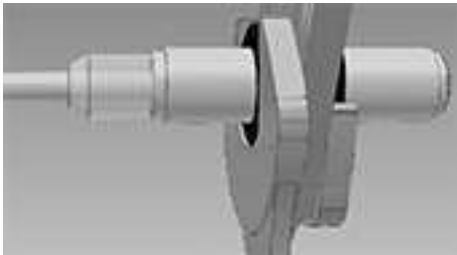

- ▶ Prevent self-loosening of the fastening elements of safety switch and actuator.
- ▶ The fastening of safety switch and actuator has to be sufficiently stable to ensure the proper operation of the safety switch and the actuator.
- ▶ The distance between two safety switches must be maintained (see [Technical details](#)  19).
- ▶ Safety switches and actuators
  - Should be kept away from iron swarf
  - Should not be exposed to strong magnetic fields
- ▶ Prevent the safety switch and actuator being exposed to heavy shock or vibration.
- ▶ Make sure that the safety switch and actuator cannot be used as an end stop.
- ▶ Circumvention of the safety switch in a reasonably foreseeable manner must be prevented.
- ▶ Please note the installation measures in accordance with EN ISO 14119 for a proximity switch type 4 with coding level Low.
- ▶ Alignment errors of the guard must not adversely affect the safety function of the guard.
- ▶ The assured operating distance  $S_{ao}$  and the assured release distance  $S_{ar}$  must be tested under real conditions.
- ▶ Do not apply any installation tools (e.g. Pliers) on the surfaces of the switch.
- ▶ If possible, do not install the safety switch and actuator on to ferromagnetic material. Changes to the operating distances are to be expected.
- ▶ Protect the safety switch and actuator from UV light or direct sunlight.
- ▶ The protection type (see [Technical details](#)  19) can only be achieved by using the Pilz connection leads available as an accessory.

### Installation of safety switch

 <p style="text-align: center;">Sensing face</p>	<p>Slide the switch through the hole in the mounting surface with the sensing face towards the actuator.</p>
	<p>Attach the switch using 2 M12 hexagonal nuts with special threads. Note the max. torque setting (see <a href="#">Technical details</a>  19).</p>

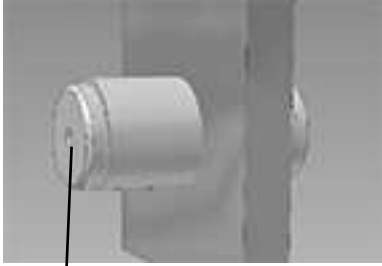
**Installation with actuator PSEN ma1.3-08**

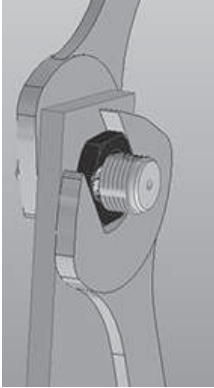
 <p>Sensing face</p>	<p>Slide the actuator through the hole in the mounting surface with the sensing face towards the safety switch.</p>
---	---

	<p>Attach the actuator using 2 M12 hexagonal nuts with special threads.</p> <p>Note the max. torque setting (see <a href="#">Technical details</a> [ 19]).</p>
--	--

**Installation with actuator PSEN ma1.3-12**

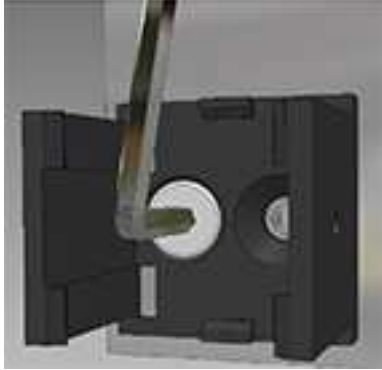
	<p>Attach the bracket using countersunk screws (M4).</p>
---	--

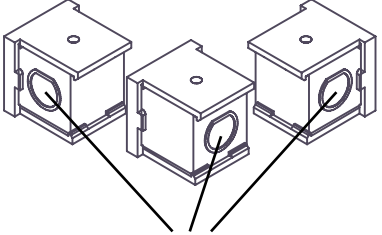
 <p>Sensing face</p>	<p>The sensing face at the actuator is marked by a circle with a bevelled surface in the shape of the safety switch. The sensing face can be aligned in 3 directions depending on the direction of actuation. Slide the actuator on to the bracket in the required direction of actuation until the actuator clicks into place.</p>
---	---

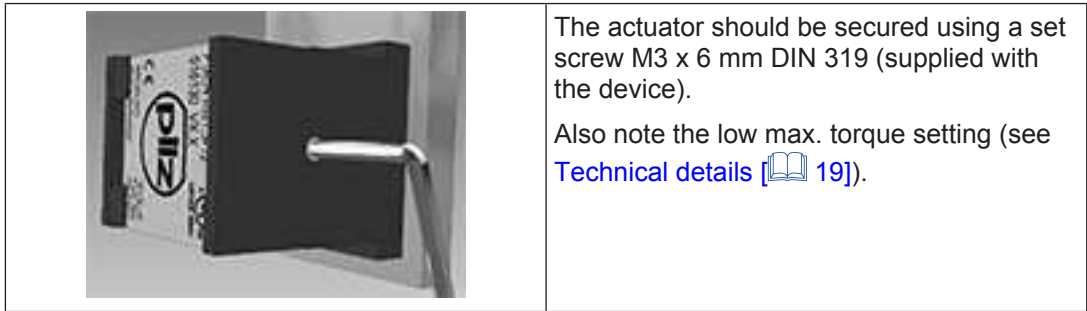

### Adjustment

- ▶ The safety switch may only be used with the corresponding actuator PSEN ma1.3-08 or PSEN ma1.3-12.
- ▶ Always test the function with a connected evaluation device.
- ▶ The stated operating distances (see [Technical details](#) [19]) only apply when the safety switch and actuator are installed according to the specifications [Installation](#) [15]. Operating distances may deviate if other arrangements are used. Note the maximum permitted lateral and vertical offset (see [Operating distances and Lateral and vertical offset](#) [8]).

### Periodic test

- ▶ Carry out a monthly function test on the safety switch and actuator.
- ▶ Always test the function with a connected evaluation device.
- ▶ The safety function may only be checked by qualified personnel.

### Dimensions in mm

#### Safety switch

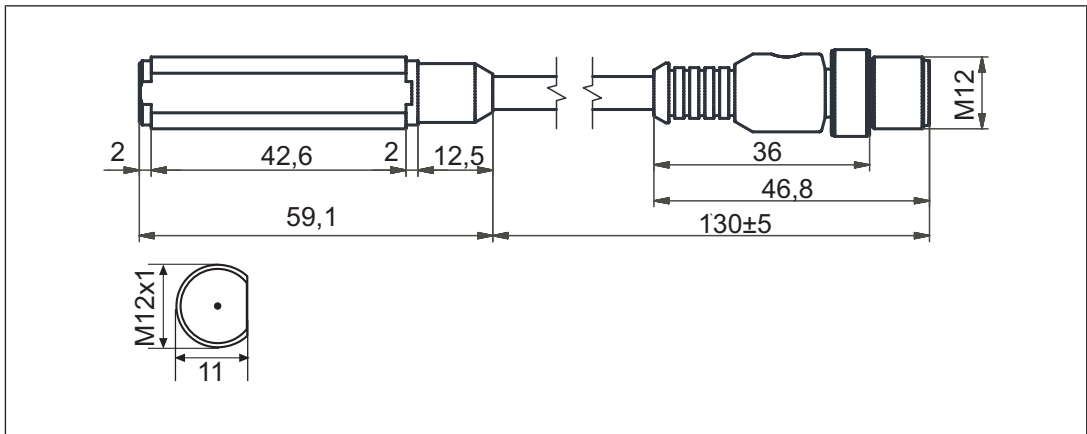

**Actuator PSEN ma1.3-08**

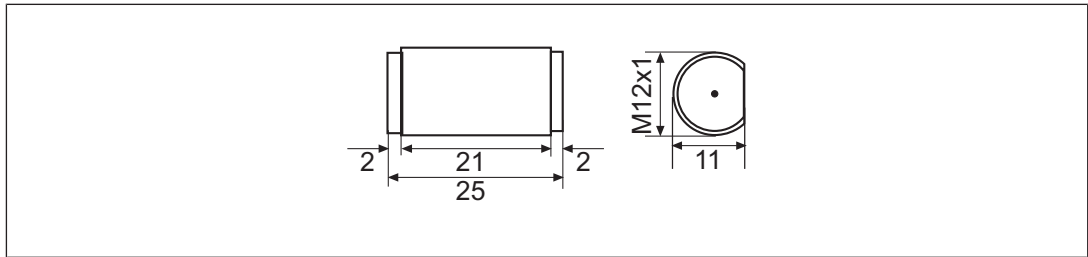

**Actuator PSEN ma1.3-12**

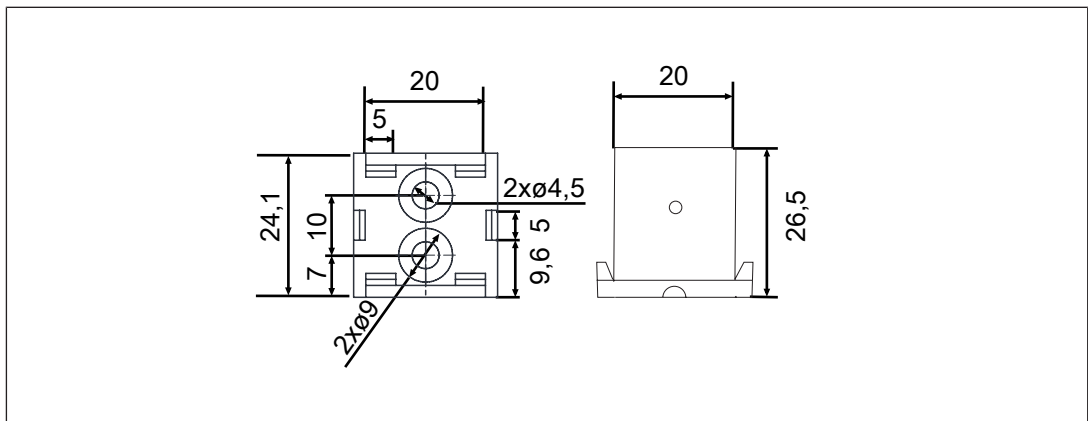
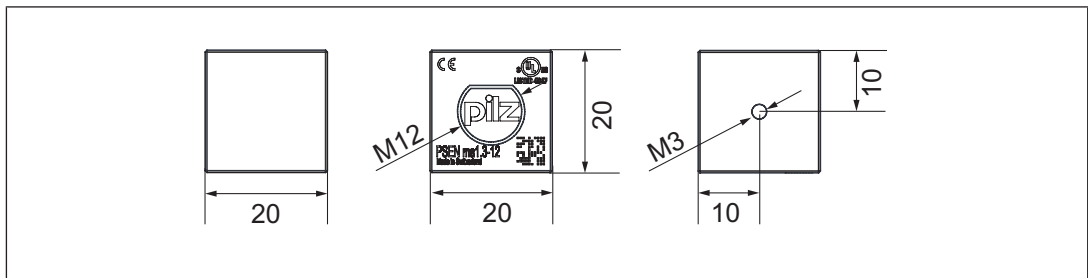

Fig.: Actuator holder

**Technical details**

General	506228	506238
Certifications	CE, EAC (Eurasian), TÜV, cULus Listed	CE, EAC (Eurasian), TÜV, cULus Listed
Sensor's mode of operation	Magnetic	Magnetic
Coding level in accordance with EN ISO 14119	Low	Low
Design in accordance with EN ISO 14119	4	4
Classification in accordance with EN 60947-5-3	PDDB	PDDB

<b>Electrical data</b>	<b>506228</b>	<b>506238</b>
Supply voltage		
Voltage	<b>24 V</b>	<b>24 V</b>
Kind	<b>DC</b>	<b>DC</b>
Voltage tolerance	<b>-20 %/+20 %</b>	<b>-20 %/+20 %</b>
Supply voltage		
Max. current	<b>150 mA</b>	<b>150 mA</b>
Max. switching frequency	<b>1 Hz</b>	<b>1 Hz</b>
Lowest operating current (I <sub>m</sub> )	<b>1 mA</b>	<b>1 mA</b>
Switching voltage	<b>24 V</b>	<b>24 V</b>
Internal resistance	<b>10 Ohm</b>	<b>10 Ohm</b>
Max. switching current, safety contacts	<b>0,2 A</b>	<b>0,2 A</b>
Max. breaking capacity, safety contacts	<b>5 W</b>	<b>5 W</b>
Max. switching current, auxiliary contacts	<b>10 mA</b>	<b>10 mA</b>
<b>Times</b>	<b>506228</b>	<b>506238</b>
Reaction time (actuator removed)	<b>2 ms</b>	<b>2 ms</b>
<b>Environmental data</b>	<b>506228</b>	<b>506238</b>
Ambient temperature		
Temperature range	<b>-25 - 70 °C</b>	<b>-25 - 70 °C</b>
Climatic suitability		
In accordance with the standard	<b>IEC 60068-2-30</b>	<b>IEC 60068-2-30</b>
Humidity	<b>93 % r. h. at 40 °C</b>	<b>93 % r. h. at 40 °C</b>
Max. operating height above sea level	<b>2000 m</b>	<b>2000 m</b>
EMC	<b>EN 60947-5-3</b>	<b>EN 60947-5-3</b>
Vibration		
In accordance with the standard	<b>EN 60947-5-2</b>	<b>EN 60947-5-2</b>
Frequency	<b>10 - 55 Hz</b>	<b>10 - 55 Hz</b>
Amplitude	<b>1 mm</b>	<b>1 mm</b>
Shock stress		
Acceleration	<b>30g</b>	<b>30g</b>
Duration	<b>11 ms</b>	<b>11 ms</b>
Airgap creepage		
Pollution degree	<b>3</b>	<b>3</b>
Rated insulation voltage	<b>125 V</b>	<b>125 V</b>
Rated impulse withstand voltage	<b>1,5 kV</b>	<b>1,5 kV</b>
Protection type		
Housing	<b>IP65</b>	<b>IP65</b>
<b>Mechanical data</b>	<b>506228</b>	<b>506238</b>
Actuator 1	<b>PSEN ma1.3-08</b>	<b>PSEN ma1.3-12</b>
Typ. Hysteresis	<b>2 mm</b>	<b>2,5 mm</b>

<b>Mechanical data</b>	<b>506228</b>	<b>506238</b>
Operating distances		
Assured operating distance Sao	<b>8 mm</b>	<b>12 mm</b>
Min. operating distance Somin	<b>0,5 mm</b>	<b>0,5 mm</b>
Typical operating distance So	<b>10 mm</b>	<b>14 mm</b>
Assured release distance Sar	<b>15 mm</b>	<b>25 mm</b>
Typical release distance Sr	<b>12 mm</b>	<b>16 mm</b>
Repetition accuracy switching distances	<b>5 %</b>	<b>5 %</b>
Min. distance between safety switches	<b>25 mm</b>	<b>35 mm</b>
Sensor flush installation in accordance with EN 60947-5-2	<b>Yes, follow installation guidelines</b>	<b>Yes, follow installation guidelines</b>
Connection type	<b>M12, 5-pin male connector</b>	<b>M12, 5-pin male connector</b>
Cable	<b>Li9Y11Y 8 x 0,14 mm<sup>2</sup></b>	<b>Li9Y11Y 8 x 0,14 mm<sup>2</sup></b>
Material		
Top	<b>PBT</b>	<b>PBT</b>
Max. torque setting		
Safety switch	<b>3 Nm</b>	<b>3 Nm</b>
Actuator 1	<b>3 Nm</b>	<b>0,1 Nm</b>
Dimensions		
Height	<b>11 mm</b>	<b>11 mm</b>
Width	<b>12 mm</b>	<b>12 mm</b>
Depth	<b>59,1 mm</b>	<b>59,1 mm</b>
Actuator dimensions		
Height	<b>11 mm</b>	<b>11 mm</b>
Width	<b>12 mm</b>	<b>12 mm</b>
Depth	<b>25 mm</b>	<b>25 mm</b>
Weight of safety switch	<b>20 g</b>	<b>20 g</b>
Weight of actuator	<b>11 g</b>	<b>26 g</b>
Weight	<b>30 g</b>	<b>42 g</b>

Where standards are undated, the 2015-09 latest editions shall apply.

#### Safety characteristic data



#### NOTICE

You must comply with the safety characteristic data in order to achieve the required safety level for your plant/machine.

**B10d in accordance with EN ISO 13849-1: 2015 and EN 62061**

7.300.000

**TM [year] in accordance with EN ISO 13849-1:2015**

20

## Order reference

### System

Product type	Features	Connection type	Order no.
PSEN ma1.3n-20/ PSEN ma1.3-08/8mm/1unit	Magnetic safety switch, actuator round, with assured operating distance 8 mm	5-pin M12 connector	506 228
PSEN ma1.3n-20/ PSEN ma1.3-12/12mm/1unit	Magnetic safety switch, actuator cube, with assured operating distance 12 mm	5-pin M12 connector	506 238
PSEN ma1.3n-20/1switch	Magnetic safety switch	5-pin M12 connector	526 128
PSEN ma1.3-08/1actuator	Actuator with assured operating distance 8 mm		516 120
PSEN ma1.3-12/1actuator	Actuator with assured operating distance 12 mm		516 130

### Accessories

#### Cable

Product type	Features	Connector X1	Connector X2	Connector X3	Order no.
PSEN op cable axial M12 5-pole 3m	3 m	M12, 5-pin female connector, straight			630 310
PSEN op cable axial M12 5-pole 5m	5 m	M12, 5-pin female connector, straight			630 311
PSEN op cable axial M12 5-pole 10m	10 m	M12, 5-pin female connector, straight			630 312
PSEN cable M12-5sf 20m	20 m	M12, 5-pin female connector, straight			630 298
PSEN op cable axial M12 5-pole 30m	30 m	M12, 5-pin female connector, straight			630 297
PSEN op cable angle M12 5-pole 3m	3 m	M12, 5-pin female connector, angled			630 347
PSEN op cable angle M12 5-pole 5m	5 m	M12, 5-pin female connector, angled			630 348
PSEN op cable angle M12 5-pole 10m	10 m	M12, 5-pin female connector, angled			630 349

Product type	Features	Connector X1	Connector X2	Connector X3	Order no.
PSEN op cable angle M12 5-pole 30m	30 m	M12, 5-pin female connector, angled			630 350
PSS67 Cable M12sf M12sm, 3m	3 m	M12, 5-pin female connector, straight	M12, 5-pin male connector, straight		380 208
PSS67 Cable M12sf M12sm, 5m	5 m	M12, 5-pin female connector, straight	M12, 5-pin male connector, straight		380 209
PSS67 Cable M12sf M12sm, 10m	10 m	M12, 5-pin female connector, straight	M12, 5-pin male connector, straight		380 210
PSS67 cable M12-5sf, M12-5sm, 20m	20 m	M12, 5-pin female connector, straight	M12, 5-pin male connector, straight		380 220
PSS67 Cable M12sf M12sm, 30m	30 m	M12, 5-pin female connector, straight	M12, 5-pin male connector, straight		380 211
PSS67 Cable M12af M12am, 3m	3 m	M12, 5-pin female connector, angled	M12, 5-pin male connector, angled		380 212
PSS67 Cable M12af M12am, 5m	5 m	M12, 5-pin female connector, angled	M12, 5-pin male connector, angled		380 213
PSS67 Cable M12af M12am, 10m	10 m	M12, 5-pin female connector, angled	M12, 5-pin male connector, angled		380 214
PSS67 Cable M12af M12am, 30m	30 m	M12, 5-pin female connector, angled	M12, 5-pin male connector, angled		380 215

### Input module

Product type	Features	Order no.
PDP67 F 8DI ION	Decentralised input module IP67 for PNOZmulti	773 600

### EC declaration of conformity

This product/these products meet the requirements of the directive 2006/42/EC for machinery of the European Parliament and of the Council. The complete EC Declaration of Conformity is available on the Internet at [www.pilz.com/downloads](http://www.pilz.com/downloads).

Authorised representative: Norbert Fröhlich, Pilz GmbH & Co. KG, Felix-Wankel-Str. 2, 73760 Ostfildern, Germany

# ► Support

Technical support is available from Pilz round the clock.

## Americas

### Brazil

+55 11 97569-2804

### Canada

+1 888-315-PILZ (315-7459)

### Mexico

+52 55 5572 1300

### USA (toll-free)

+1 877-PILZUSA (745-9872)

## Asia

### China

+86 21 60880878-216

### Japan

+81 45 471-2281

### South Korea

+82 31 450 0680

## Australia

+61 3 95600621

## Europe

### Austria

+43 1 7986263-0

### Belgium, Luxembourg

+32 9 3217575

### France

+33 3 88104000

### Germany

+49 711 3409-444

### Ireland

+353 21 4804983

### Italy, Malta

+39 0362 1826711

## Scandinavia

+45 74436332

## Spain

+34 938497433

## Switzerland

+41 62 88979-30

## The Netherlands

+31 347 320477

## Turkey

+90 216 5775552

## United Kingdom

+44 1536 462203

### You can reach our international hotline on:

+49 711 3409-444

support@pilz.com

Pilz develops environmentally-friendly products using ecological materials and energy-saving technologies. Offices and production facilities are ecologically designed, environmentally-aware and energy-saving. So Pilz offers sustainability, plus the security of using energy-efficient products and environmentally-friendly solutions.

*Energy*  
saving by Pilz



Pilz GmbH & Co. KG  
Felix-Wankel-Straße 2  
73760 Ostfildern, Germany  
Tel.: +49 711 3409-0  
Fax: +49 711 3409-133  
info@pilz.com  
www.pilz.com

**PILZ**  
THE SPIRIT OF SAFETY

CMSE®, InduraNET p®, PAS4000®, PASscal®, PASconfig®, Pilz®, PIT®, PLID®, PMCPprime®, PMCPprotect®, PMCiendo®, PMD®, PMi®, PNOZ®, Pirmo®, PSEN®, PSENi®, PSS®, PViS®, SafetyBUS SafetyEYE®, SafetyNET p®, THE SPIRIT OF SAFETY® are registered and protected trademarks of Pilz GmbH & Co. KG in some countries. We would point out that product features mentioned in the details stated in this document, depending on the status at the time of publication and the scope of the equipment. We accept no responsibility for the validity, accuracy and entirety of the text and graphics presented in this information. Please contact our Technical Support if you have any questions.